



Models B530AP & B530SS

Ice Storage Bin



Features:

- Space saving design – only 30" wide
- Low profile
- Quality construction
- One piece rotomolded cabinet
- Non-CFC foam insulation
- Corrosion proof
- Virtually indestructible
- Stainless steel door

Options Available

- B530SS
- Stainless steel cabinet
- High impact polyethylene liner
- Microban antimicrobial product protection inhibits bacteria, mold and mildew

Microban® is a registered trademark of the Microban Products Company, Huntersville, NC.



Model B530AP & B530SS

Technical Specifications:

Certified Cube Storage Capacity:

B530AP: 360 lbs. (163 kgs.) certified in accordance with ARI Standard 820-88

B530SS: 400 lbs. (181 kgs.) certified in accordance with ARI Standard 820-88

Drain Connection: 3/4" (2 cm) fitting can be adapted to plastic, copper or galvanized drain line

Cabinet Finish:

B530AP: Polyethylene exterior and interior bin liner. Stainless steel door.

B530SS: Stainless steel exterior with polyethylene bin liner. Stainless steel door.

Ice Storage Capacity: 500 lbs. (226 kgs.)

Operating Weight: 92 lbs. (42 kgs.)

Shipping Weight: 108 lbs. (49 kgs.)

Agency Listings:

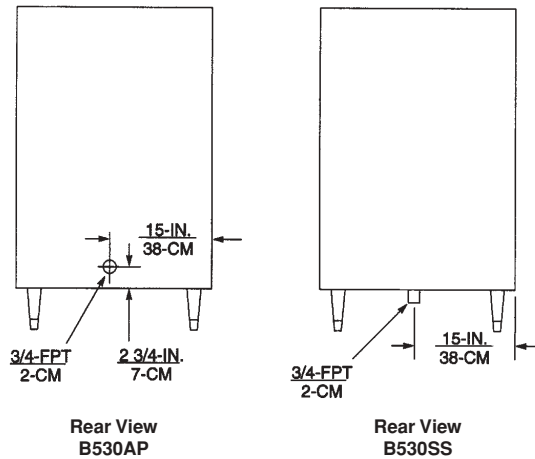
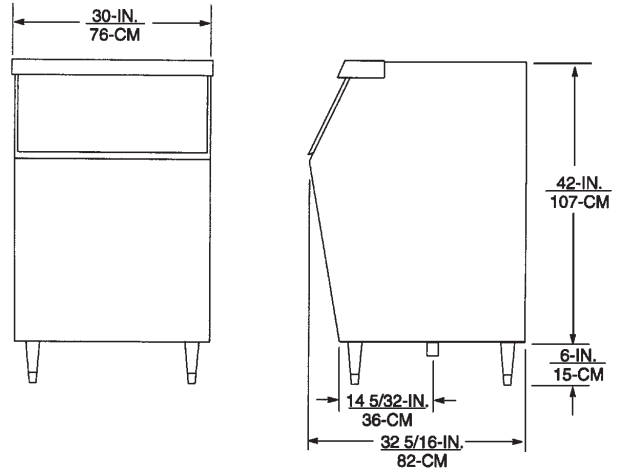

Part No.	Description	Ice Maker Application
B530AP	Ice Storage Bin	330/530/630 Cuber series
B530SS	Ice Storage Bin	330/530/630 Cuber series



For more information or to place an order, contact your sales representative or authorized distributor.

In the US:
 Phone: 1-800-238-3600
 Fax: 1-800-535-4235
Outside the US:
 Phone: 1-763-421-6120
 Fax: 1-763-422-3297

IMI Cornelius Inc.
 One Cornelius Place
 Anoka, MN 55303-6234
 USA