



Models B1315SBB

Ice Storage Bin



Features:

- High impact design – dependable storage for cube or flake ice
- Quality construction
- Stainless steel cabinet
- Roto molded poly pouch/door assembly
- High impact polyethylene lining – virtually indestructible
- View window for instant inspection
- Fully gasketed bin
- Easy to clean and sanitize



Model B1315SBB

Technical Specifications:

Certified Cube Storage Capacity: 1160 lbs. (526.2 kgs.)
certified in accordance with ARI Standard 820-88

Drain Connection: 1" (3 cm) fitting can be adapted to plastic, copper or galvanized drain line

Cabinet Finish: B1315SBB: Stainless steel exterior with polyethylene bin liner

Ice storage capacity: 1315 lbs. (596.5 kgs.)

Operating Weight: 325 lbs. (147 kgs.)

Shipping Weight: 360 lbs. (164 kgs.)

Agency Listings

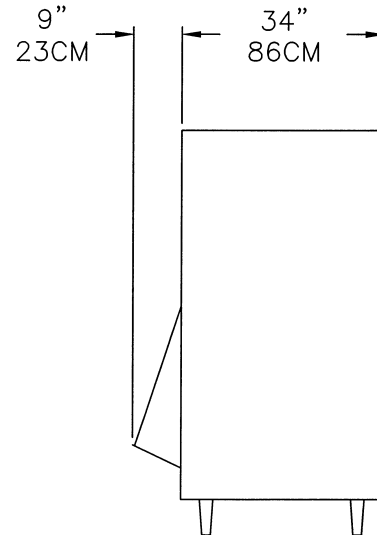
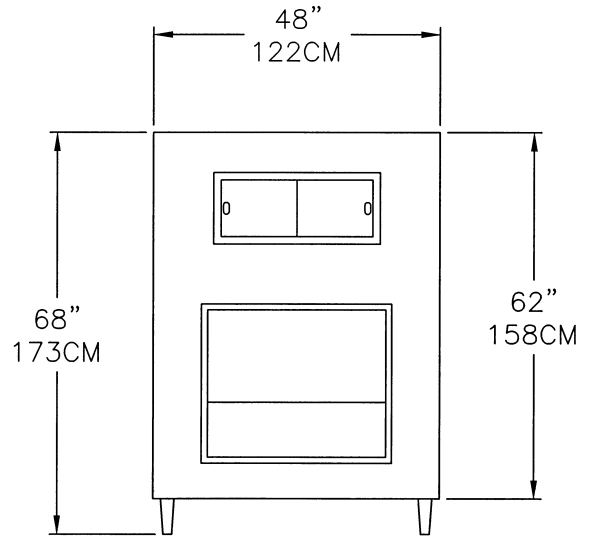

Part No.	Description	Ice Maker Application
569200172	Ice Storage Bin B1315SBB	*1448 and 2448 Cuber Series

*Bin adapter included



For more information or to place an order, contact your sales representative or authorized distributor:

In the U.S.:
 Phone: 1-800-238-3600
 Fax: 1-800-535-4235
Outside the U.S.:
 Phone: 1-612-421-6120
 Fax: 1-612-422-3297

IMI Cornelius, Inc.
 One Cornelius Place
 Anoka, MN 55303-6234
 USA