

Models B1048P & B1048SS

Ice Storage Bin



Features:

- High impact design – dependable storage for cube or flake ice
- Quality construction
- Gray baked enamel cabinet finish
- Stainless steel door
- High impact polyethylene lining – virtually indestructible
- Non-CFC foam insulation
- Optional stainless steel cabinet
- Easy to clean and sanitize



Model B1048P & B1048SS

Technical Specifications:

Certified Cube Storage Capacity: 670 lbs. (304 kgs.) certified in accordance with ARI Standard 820-88

Drain Connection: 1" (3 cm) fitting can be adapted to plastic, copper or galvanized drain line

Cabinet Finish:

B1048P: Gray baked enamel exterior with polyethylene bin liner. Stainless steel door

B1048SS: Stainless steel exterior with polyethylene bin liner. Stainless steel door

Ice Storage Capacity: 1000 lbs. (455 kgs.)

Operating Weight: 147 lbs. (67 kgs.)

Shipping Weight: 182 lbs. (83 kgs.)

Agency Listings:

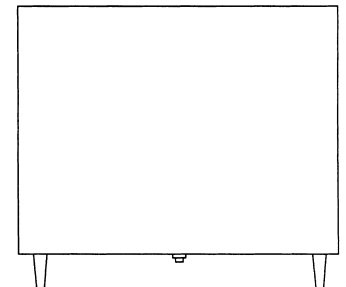
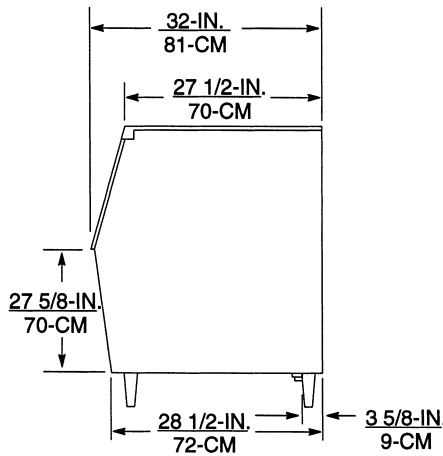
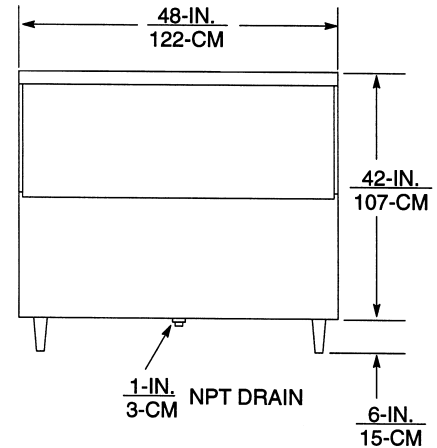

Part No.	Description	Ice Maker Application
B1048P	Ice Storage Bin	*630/*830/*1030/*1230/*1448 Cuber series
B1048SS	Ice Storage Bin	*700/*1100 Flaker series

* Requires bin adapter



For more information or to place an order, contact your sales representative or authorized distributor.

In the US:

Phone: 1-800-238-3600

Fax: 1-800-535-4235

Outside the US:

Phone: 1-612-421-6120

Fax: 1-612-422-3297

IMI Cornelius Inc.

One Cornelius Place
Anoka, MN 55303-6234
USA